

brother

PARTS BOOK

LE2-B861



Embroidery Sewing Machine



BROTHER INDUSTRIES, LTD.
NAGOYA, JAPAN

From the library of: Superior Sewing Machine & Supply LLC

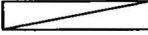

Notes for using this parts book

1. If the symbol  is found in the "Parts No." column or the "Assembly No." column, refer to the different parts list on page 7.
2. The symbol  in the "Parts No." column indicates that the parts is not available for supply. If, however, there is a number in the "Assembly No." column, the parts can be ordered as an assembly. Please, therefore, order by using the Assembly No.
3. This book was prepared based on information available in September, 1981.
4. Parts are subject to changes in design without prior notice.

Anmerkungen zum Gebrauch dieses Stücklistebuches

1. Dieses Zeichen  in der Spalte "Parts No. (Teilnummer)" oder "Assembly No. (Gerätesatznummer)" verweist auf die Gesonderte Stückliste auf Seite 7.
2. Dieses Zeichen  in der Spalte "Teilnummer" bedeutet, daß dieser Teil nicht lieferbar ist. Wenn Jedoch in der Spalte "Gerätesatznummer" eine Nummer steht, kann dieser Teil als ein Geräteteilsatz bestellt werden. Bestellen Sie daher bitte mit dieser Gerätesatznummer.
3. Dieses Buch basiert auf den Informationen vom September, 1981.
4. Modelländerungen sind vorbehalten.

Notes sur l'utilisation de ce manuel de pièces détachées

1. Si le symbole  se trouve dans la colonne "Parts No. (N° de pièce)" ou dans la colonne "Assembly No. (N° jeu de pces)", veuillez vous référer à la liste de pièces annexe page 7.
2. Le symbole  dans la colonne "N° de pièce" signifie que la pièce ne peut être fournie. Si, dans la colonne "N° jeu de pces", il y a un numéro de nomenclature, la pièce peut être commandée comme faisant partie d'un jeu de pièces. Donc, pour toute commande, veuillez spécifier le N° du jeu de pièces.
3. Ce manuel a été fait d'après les renseignements valables au mois de Septembre, 1981.
4. Les pièces peuvent être sujettes à des modifications sans préavis.

Notas para usar este Libro de Piezas

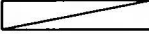
1. De haber un símbolo  junto al "Parts No. (Número de Pieza)" o en la columna del "Assembly No. (Número de Juego)", habrá que mirar la lista de piezas separada de la página 7.
2. El símbolo , que se encuentra en la columna del "Número de Pieza", quiere decir que no se dispone de dicha pieza sola. Cuando, empero, hay un número en la columna del "Número de Juego", se podrá ordenar la pieza con todo el juego. Por lo tanto, será mejor hacer el pedido recurriendo al número del juego respectivo.
3. Este libro ha sido compilado basándose en los datos de que se disponía en Septiembre de 1981.
4. Las piezas quedan sujetas a cambios de diseño sin aviso previo.

CONTENTS

A. Machine Body	1
B. Needle Bar and Thread Take-up Mechanism	2
C. Rotary Hook Mechanism	3
D. Zigzag and Knee Lifter Mechanism	4
E. Lubrication	5
Z. Accessories	6
DIFFERENT PARTS LIST	7
INDEX	7

A. Machine Body

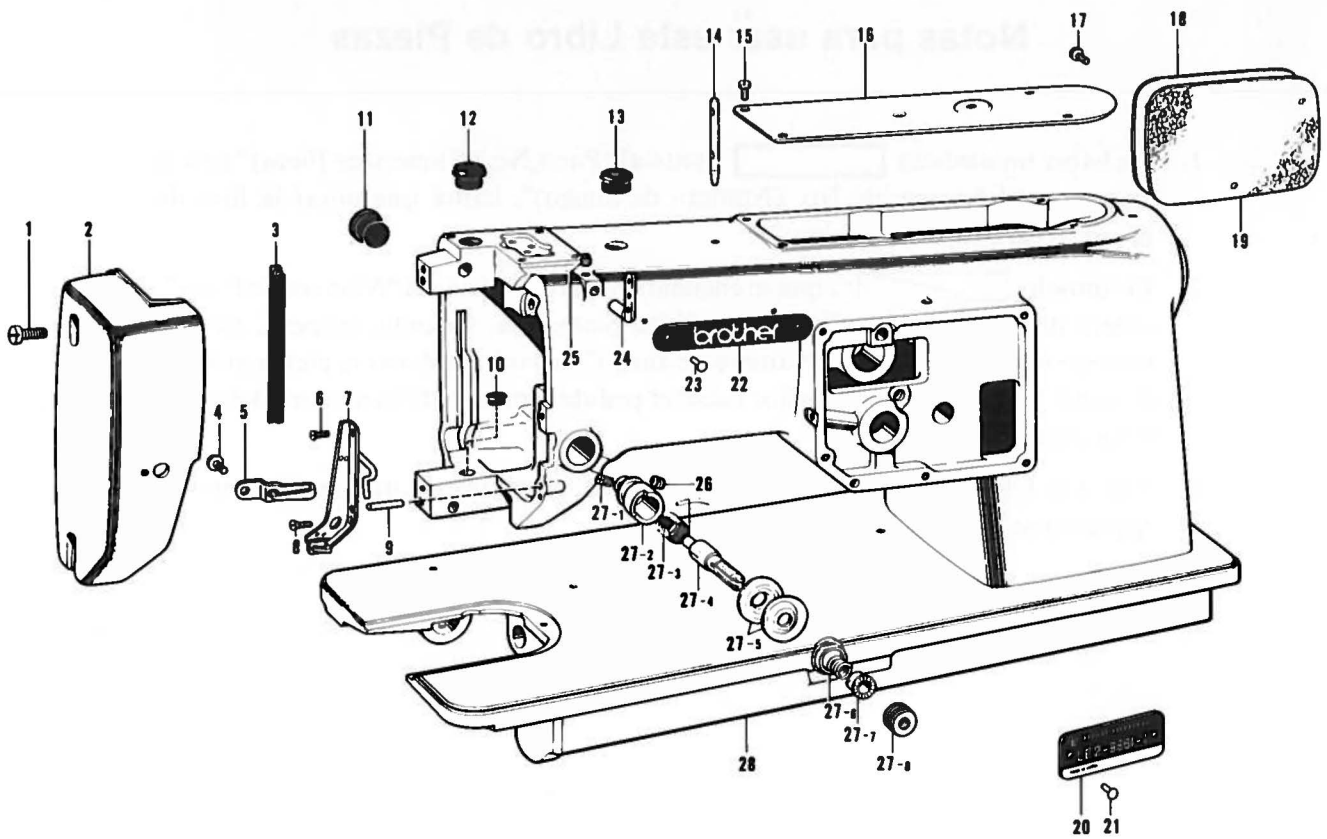

Ref. No.	Name of Parts	Q'ty	Parts No.	Assembly No.	Ref. No.	Name of Parts	Q'ty	Parts No.	Assembly No.
A- 1	Screw 4.76	2	107474-0-02		A-19	Packing	1	116981-0-00	
A- 2	Face Plate	1	117533-1-01		A-20	Model Plate	1		
A- 3	Oil Cap	1	117935-0-01		A-21	Pin	2		
A- 4	Screw 3.57 x 4	1	009670-4-12		A-22	Name Plate	1		
A- 5	Face Plate Thread Guide	1	117636-0-01		A-23	Model Plate Pin	2		
A- 6	Screw 2.38	1	102731-0-02		A-24	Thread Retainer	1	114931-0-02	
A- 7	Thread Guide Assembly	1	117637-0-01		A-25	Screw 4.37	1	151601-0-02	
A- 8	Screw 3.57	1	108960-0-04		A-26	Screw 5.95	1	103950-0-02	
A- 9	Pin	1	117640-0-01		A-27-1	Screw 3.57	1	100402-0-04	
A-10	Oil Cap	1	117936-0-01		A-27-2	Upper Tension Regulator Bracket	1	145250-0-01	
A-11	Oil Cap	2	104449-0-01		A-27-3	Thread Take-up Spring	1	118197-0-01	A-27
A-12	Oil Cap	1	117934-0-01		A-27-4	Tension Stud	1	117632-0-01	Tension
A-13	Oil Cap	1	111937-0-01		A-27-5	Tension Disc	2	145446-0-01	Regulator
A-14	Spool Pin	1	100386-0-01		A-27-6	Tension Spring	1	117633-0-01	Assembly
A-15	Screw 3.57	4	100257-0-10		A-27-7	Tension Spring Washer	1	144105-0-00	158025-0-01
A-16	Top Cover	1	117534-0-02		A-27-8	Nut	1	151012-0-01	
A-17	Screw 3.57	3	100257-0-10		A-28	Arm Bed	1		
A-18	Rear Cover	1	148919-0-02						

B. Needle Bar and Thread Take-up Mechanism

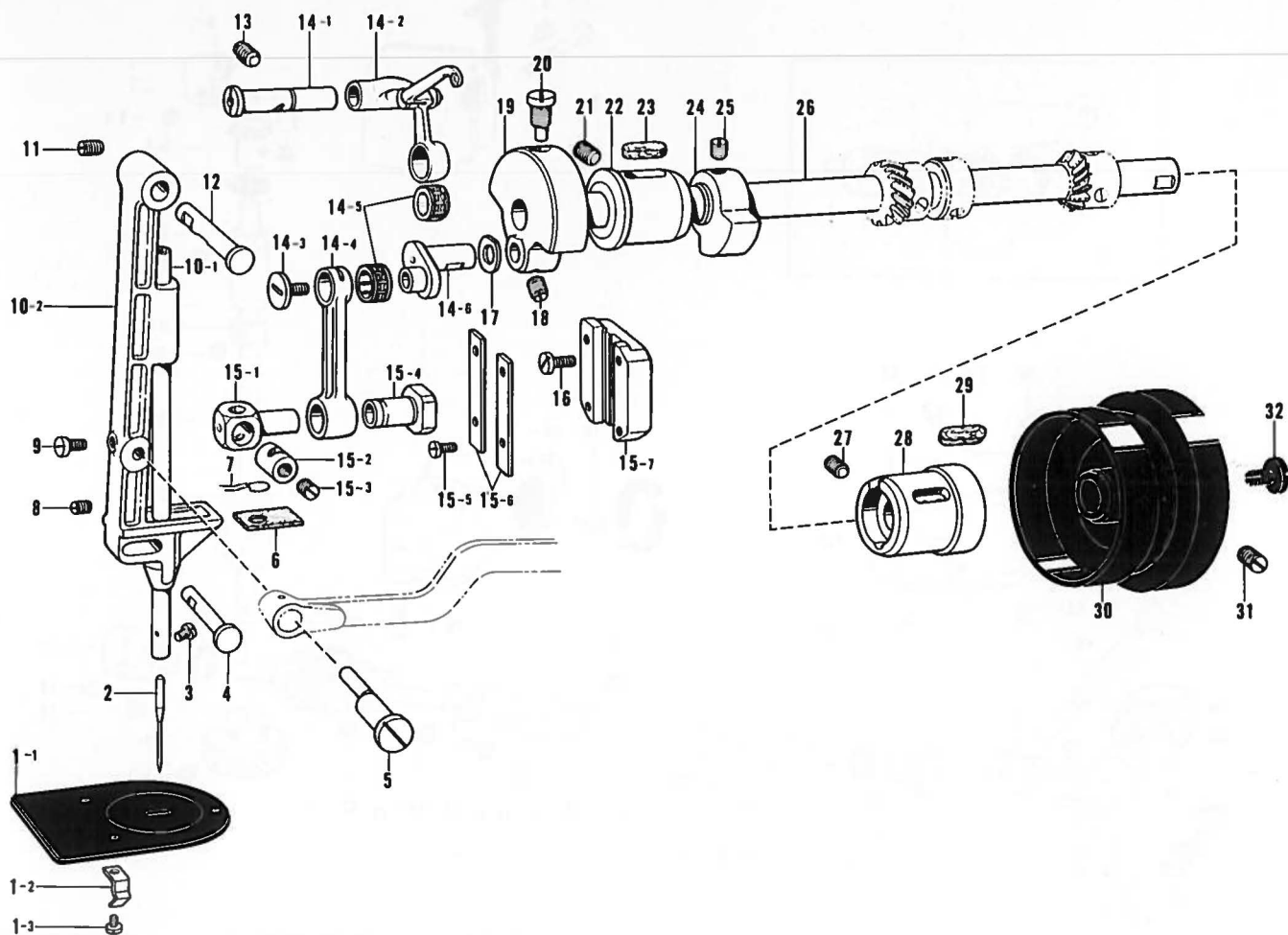

Ref. No.	Name of Parts	Q'ty	Parts No.	Assembly No.	Ref. No.	Name of Parts	Q'ty	Parts No.	Assembly No.
B- 1-1	Needle Plate	1		B-1 Needle Plate Assembly 148309-0-01	B-15-2	Needle Bar Clamp	1	147646-0-01	B-15 Slide Block Guide Assembly 118807-1-01
B- 1-2	Spring	1	148310-0-01		B-15-3	Screw 5.56	1	110124-0-01	
B- 1-3	Screw 2.38	2	122771-0-02		B-15-4	Slide Block	1	118791-0-01	
B- 2	Needle #11	1			B-15-5	Screw 3.18	4	100080-0-03	
B- 3	Screw 3.18	1	140553-0-01		B-15-6	Slide Block Presser Plate	2	147732-0-01	
B- 4	Pin D	1	113031-0-01		B-15-7	Slide Block Guide	1		
B- 5	Eccentric Shaft	1	117549-0-01		B-16	Screw 4.37	2	107407-0-03	
B- 6	Felt A	1	117547-0-01		B-17	Washer	1	110367-0-01	
B- 7	Spring	1	118311-0-01		B-18	Screw 6.35	2	100251-0-01	
B- 8	Screw 4.76	1	013711-0-10		B-19	Thread Take-up Crank	1	117543-0-00	
B- 9	Screw 5.95	1	105163-0-01		B-20	Screw 7.14	1	100250-0-01	
B-10-1	Needle Bar	1		B-10 Needle Bar Support Assembly	B-21	Screw 5.95	1	013761-4-10	
B-10-2	Needle Bar Support	1			B-22	Upper Shaft Bushing Left	1	117937-0-01	
B-11	Screw 4.76	1	013711-0-10		B-23	Felt	1	100248-0-01	
B-12	Pin U	1	117939-0-01		B-24	Counter Weight	1	117542-0-00	
B-13	Screw 5.95	1	151605-0-01		B-25	Screw 6.35	2	013780-8-10	
B-14-1	Stud	1	117553-0-01		B-26	Upper Shaft	1	117535-0-01	
B-14-2	Thread Take-up Lever Assembly	1		B-14 Needle Bar Connecting Lever Assembly 117550-0-01	B-27	Screw 5.95	1	013760-6-10	
B-14-3	Screw 3.57	1	145465-0-01		B-28	Upper Shaft Bushing Right	1	117938-0-01	
B-14-4	Needle Bar Crank Rod	1	118793-0-01		B-29	Felt	1	100248-0-01	
B-14-5	Needle Roller Bearing	2	116735-0-00		B-30	Pulley	1	117941-0-01	
B-14-6	Needle Bar Crank	1			B-31	Screw 5.95	2	013761-4-10	
B-15-1	Needle Bar Clamp Shaft	1	117560-0-01	B-15 118807-1-01	B-32	Screw 8.73	1	104478-0-01	

C. Rotary Hook Mechanism

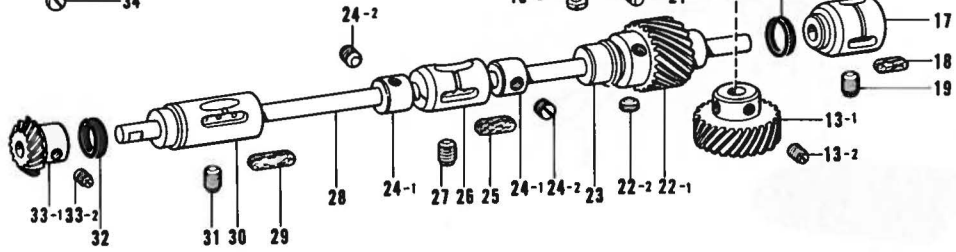
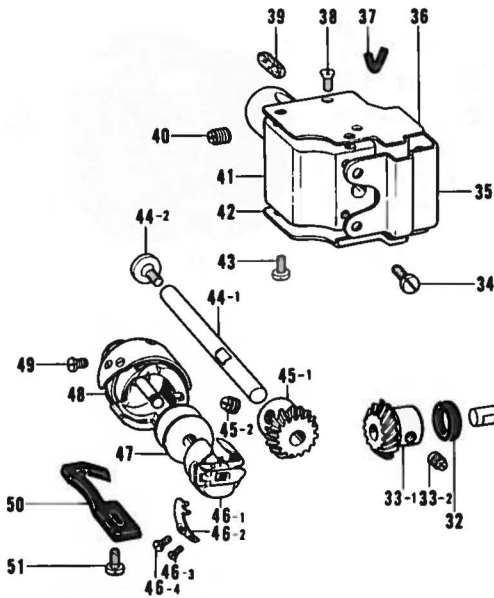
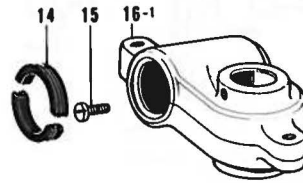
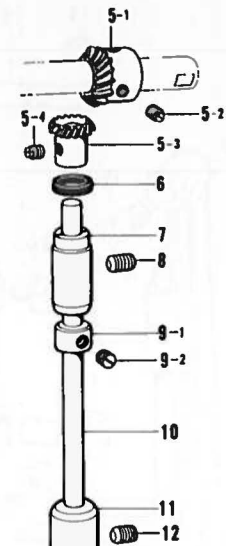
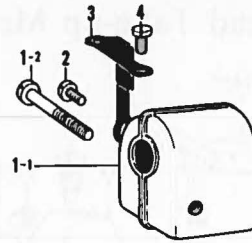
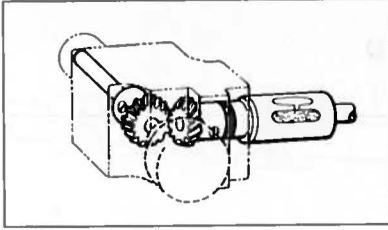

Ref. No.	Name of Parts	Q'ty	Parts No.	Assembly No.	Ref. No.	Name of Parts	Q'ty	Parts No.	Assembly No.
C- 1-1	Upper Gear Case	1		C-1 Gear Case Assembly 118280-1-01	C-25	Felt	1	100633-0-01	
C- 1-2	Screw 6.35 x 30	1	009783-0-12		C-26	Lower Shaft Bushing Middle	1	117582-0-01	
C- 2	Screw 6.35 x 8	1	009780-8-12		C-27	Screw 5.95	1	151605-0-01	
C- 3	Gear Case Supporter	1	117945-0-01		C-28	Lower Shaft	1	117577-0-01	
C- 4	Screw 3.57 x 6	2	001670-6-12		C-29	Felt	1	100633-0-01	
C- 5-1	Upper Shaft Gear	1		C-5 Upper Shaft Gear Assembly 118278-0-01	C-30	Lower Shaft Bushing Left	1	117583-0-01	
C- 5-2	Screw 6.35	2	100251-0-01		C-31	Screw 5.95	1	151605-0-01	
C- 5-3	Vertical Shaft Upper Gear	1			C-32	Seal	1	117584-0-01	
C- 5-4	Screw 6.35	2	103790-0-01		C-33-1	Lower Shaft Gear	1		C-33 Lower Shaft Gear Assembly 118285-0-01
C- 6	Seal	1	103796-0-01		C-33-2	Screw 6.35	2	101706-0-01	
C- 7	Vertical Shaft Bushing Upper	1	117570-0-01		C-34	Screw 3.57 x 6	4	009670-6-13	
C- 8	Screw 5.95	2	013760-6-10		C-35	Gear Case	1	117587-0-01	
C- 9-1	Vertical Shaft Set Collar	1		C-9 Set Collar Assembly 118299-0-01	C-36	Gear Case Cover Upper	1	117588-0-01	
C- 9-2	Screw 6.35	2	101706-0-03		C-37	Wick 4 x 4 (26 mm)	1	117591-0-01	
C-10	Vertical Shaft	1	117569-0-01		C-38	Screw 3.57	2	102843-0-02	
C-11	Vertical Shaft Bushing Lower	1	117571-0-01		C-39	Felt	1	100633-0-01	
C-12	Screw 5.95	2	013761-4-10		C-40	Screw 5.95	2	151605-0-01	
C-13-1	Vertical Shaft Gear	1		C-13 Vertical Shaft Driving Gear Assembly 118279-0-01	C-41	Rotary Hook Shaft Bushing	1	117590-0-01	
C-13-2	Screw 6.35	2	100251-0-01		C-42	Gear Case Cover Lower	1	117589-0-01	
C-14	Gear Case Seal	1	140536-0-01		C-43	Screw 3.57 x 6	3	009670-6-13	
C-15	Screw 4.76	1	013711-0-10		C-44-1	Rotary Hook Shaft	1		C-44 Rotary Hook Shaft Assembly 117592-0-01
C-16-1	Lower Gear Case	1		C-16 Gear Case Assembly 140740-0-01	C-44-2	Screw 3.57	1	145465-0-01	
C-16-2	Screw 6.35 x 18	2	009781-8-12		C-45-1	Rotary Hook Shaft Gear	1		C-45 Hook Driving Gear Assembly 118286-0-01
C-17	Lower Shaft Bushing Right	1	117580-0-01		C-45-2	Screw 6.35	3	101706-0-01	
C-18	Felt	1	117581-0-01		C-46-1	Bobbin Case	1		C-46 Bobbin Case Assembly 117596-0-01
C-19	Screw 5.95	1	151605-0-01		C-46-2	Lower Thread Adjusting Spring	1	182392-0-01	
C-20	Seal	1	117584-0-01		C-46-3	Spring Set Screw	1	181938-0-01	
C-21	Screw 5.95	2	151604-0-01		C-46-4	Spring Adjusting Screw	1	181937-0-01	
C-22-1	Lower Shaft Gear	1		C-22 Lower Shaft Gear Assembly 180973-0-01	C-47	Bobbin	1	146290-0-01	
C-22-2	Screw 6.35	2	105299-0-03		C-48	Rotary Hook Assembly	1	117677-0-01	
C-23	Gear Sleeve	1	117946-0-00		C-49	Screw 4.37	3	117594-0-01	
C-24-1	Vertical Shaft Set Collar	2		C-24 Set Collar Assembly 118299-0-01	C-50	Bobbin Case Holder Position Bracket	1	117595-0-01	
C-24-2	Screw 6.35	4	101706-0-03		C-51	Screw 4.37	1	107407-0-03	

D. Zigzag and Knee Lifter Mechanism

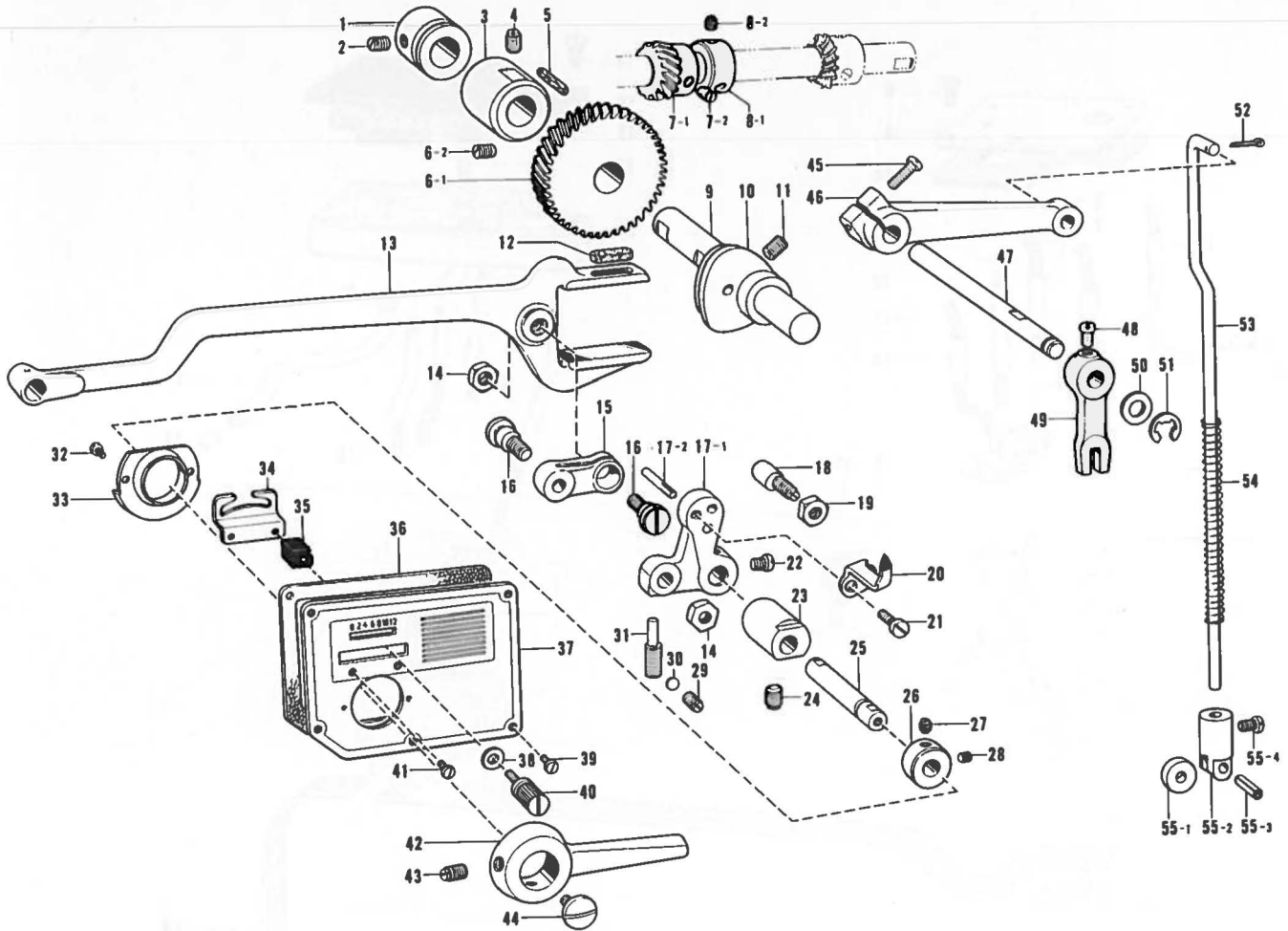

Ref. No.	Name of Parts	Q'ty	Parts No.	Assembly No.	Ref. No.	Name of Parts	Q'ty	Parts No.	Assembly No.
D- 1	Collar	1	117947-0-01		D-26	Set Collar	1	117611-0-00	
D- 2	Screw 6.35	2	101706-0-01		D-27	Screw 6.35	1	123006-0-01	
D- 3	Zigzag Shaft Bushing	1	117603-0-00		D-28	Screw 6.35	1	105299-0-03	
D- 4	Screw 5.95	1	151605-0-01		D-29	Screw 4.37	1	151603-0-02	
D- 5	Felt	1	100633-0-01		D-30	Washer	1	100507-0-00	
D- 6-1	Zigzag Shaft Driving Gear	1		D-6 Zigzag Cam Shaft Gear Assembly 180975-0-01	D-31	Screw	1	117613-0-01	
D- 6-2	Screw 6.35	2	101706-0-01		D-32	Screw 3.18 x 3	2	009660-3-12	
D- 7-1	Zigzag Shaft Gear	1		D-7 Upper Shaft Gear Assembly (Z) 180974-0-01	D-33	Zigzag Transverse Shaft Cover	1	140521-0-01	
D- 7-2	Screw 6.35	2	101706-0-01		D-34	Supporter	1	117618-0-01	
D- 8-1	Collar	1		D-8 Pulley Bush Assembly 118371-0-01	D-35	Nut	2	117617-0-01	
D- 8-2	Screw 6.35	2	100251-0-01		D-36	Packing	1	117620-0-00	
D- 9	Zigzag Shaft	1	117600-0-01		D-37	Panel	1	117619-0-01	
D-10	Zigzag Cam	1	117599-0-00		D-38	Washer	2	117948-0-00	
D-11	Screw 5.95	2	013760-6-10		D-39	Screw 3.57	5	100257-0-10	
D-12	Felt	1	117598-0-01		D-40	Screw	2	117616-0-01	
D-13	Zigzag Fork Rod	1	117597-0-01		D-41	Screw 3.57	2	100257-0-10	
D-14	Nut 7.14	2	104689-0-01		D-42	Zigzag Transverse Lever	1	117612-0-01	
D-15	Feed Link	1	147649-0-01		D-43	Screw 5.95	2	151604-0-02	
D-16	Screw 7.14	2	145486-0-01		D-44	Screw 4.76	1	100511-0-01	
D-17-1	Link B	1	147648-0-01	D-17 Zigzag Transverse Link B Assembly 147647-0-01	D-45	Screw 4.37 x 16	1	009681-6-12	
D-17-2	Pin	1	117608-0-01		D-46	Knee Lifter	1	117566-0-01	
D-18	Screw	1	117614-0-01		D-47	Knee Lifter Shaft	1	117563-0-01	
D-19	Nut 5.95	1	106588-0-01		D-48	Screw 4.37	2	104908-0-01	
D-20	Indicator	1	117615-0-01		D-49	Knee Lifter Shaft Fork	1	117565-0-01	
D-21	Screw 4.37	1	106629-0-01		D-50	Washer	1	116629-0-01	
D-22	Screw 4.37	2	104908-0-01		D-51	Stop Ring E6	1	048060-3-42	
D-23	Zigzag Transverse Shaft Bushing	1	117610-0-01		D-52	Pin	1	114909-0-00	
D-24	Screw 5.95	1	151605-0-01		D-53	Knee Lifter Complying Bar	1	117567-0-01	
D-25	Zigzag Transverse Shaft	1	117609-0-01		D-54	Spring	1	117568-0-01	
					D-55-1	Roller	1	112636-0-01	D-55 Knee Lifter Roller Bracket Assembly 151609-0-01
					D-55-2	Roller Bracket	1		
					D-55-3	Pin AW5	1	047501-2-42	
					D-55-4	Screw 4.37	1	151601-0-02	

E. Lubrication

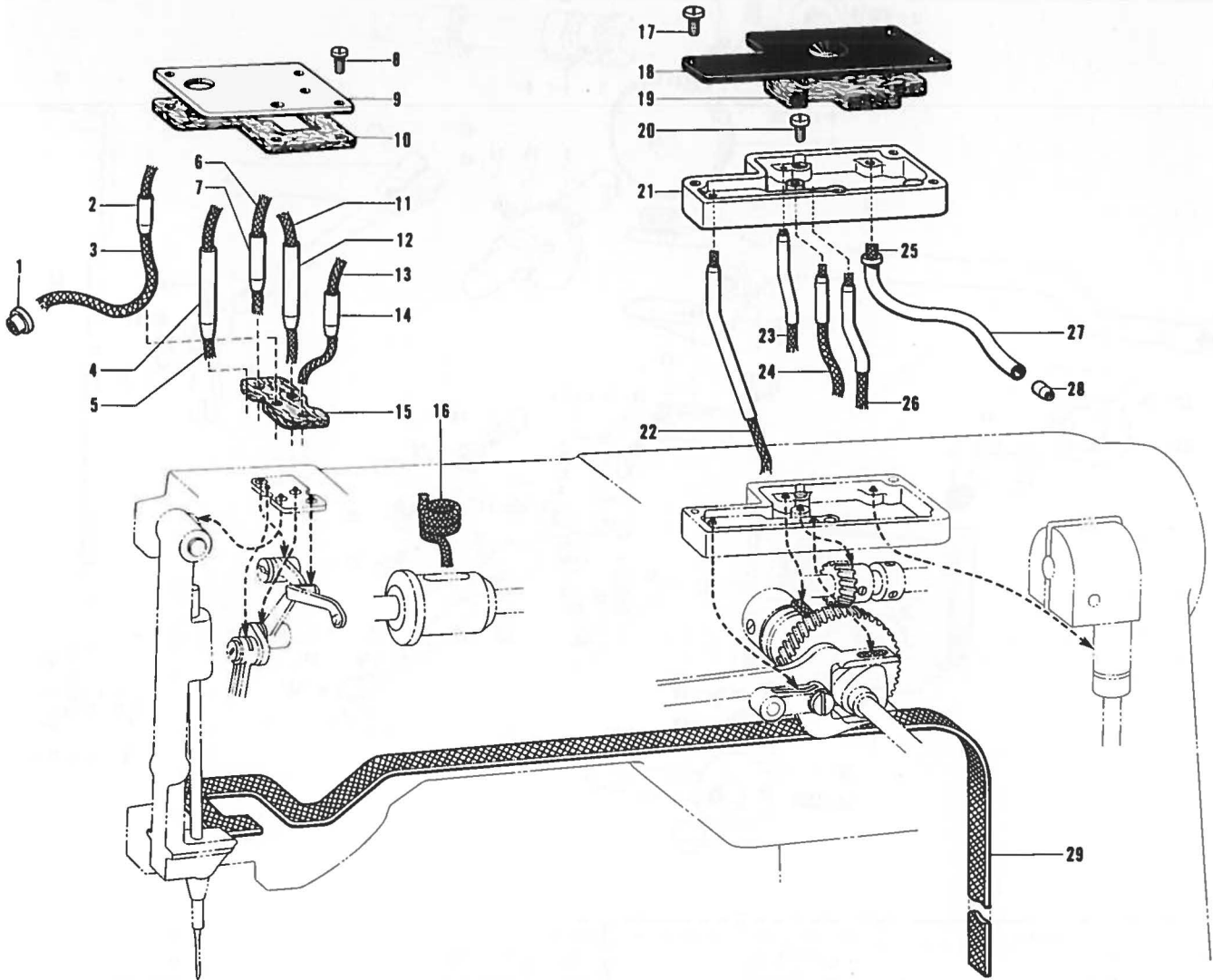

Ref. No.	Name of Parts	Q'ty	Parts No.	Assembly No.	Ref. No.	Name of Parts	Q'ty	Parts No.	Assembly No.
E-1	Wick Nipper	1	109993-0-01		E-16	Wick 6 x 6 (100 mm)	1	108808-0-01	
E-2	Oil Pipe	1	117656-0-00		E-17	Screw 3.57 x 6	3	001670-6-12	
E-3	Wick 4 x 4 (80 mm)	1	117007-0-01		E-18	Oil Tank Lid	1	117958-0-01	
E-4	Oil Pipe	1	116966-0-00		E-19	Felt	1	117957-0-01	
E-5	Wick 4 x 4 (60 mm)	1	117006-0-01		E-20	Screw 3.57 x 14	2	009671-4-12	
E-6	Wick 4 x 4 (35 mm)	1	111191-0-01		E-21	Oil Tank	1	117953-0-01	
E-7	Oil Pipe	1	116967-0-00		E-22	Wick 4 x 4 (170 mm)	1	152973-0-01	
E-8	Screw 3.57	4	100257-0-10		E-23	Wick 4 x 4 (140 mm)	1	148302-0-01	
E-9	Oil Tank Lid	1	117643-0-01		E-24	Wick 4 x 4 (100 mm)	1	109405-0-01	
E-10	Packing	1	117644-0-00		E-25	Wick 4 x 4 (170 mm)	1	152973-0-01	
E-11	Wick 4 x 4 (60 mm)	1	117006-0-01		E-26	Wick 4 x 4 (120 mm)	1	112999-0-00	
E-12	Oil Pipe	1	116969-0-00		E-27	Vinyl Tube	1	116984-0-00	
E-13	Wick 4 x 4 (26 mm)	1	117591-0-01		E-28	Oil Pipe	1	116968-0-00	
E-14	Oil Pipe	1	116968-0-00		E-29	Wick 2 x 2 (500 mm)	1	117022-0-01	
E-15	Felt	1	117642-0-01						

Z. Accessories

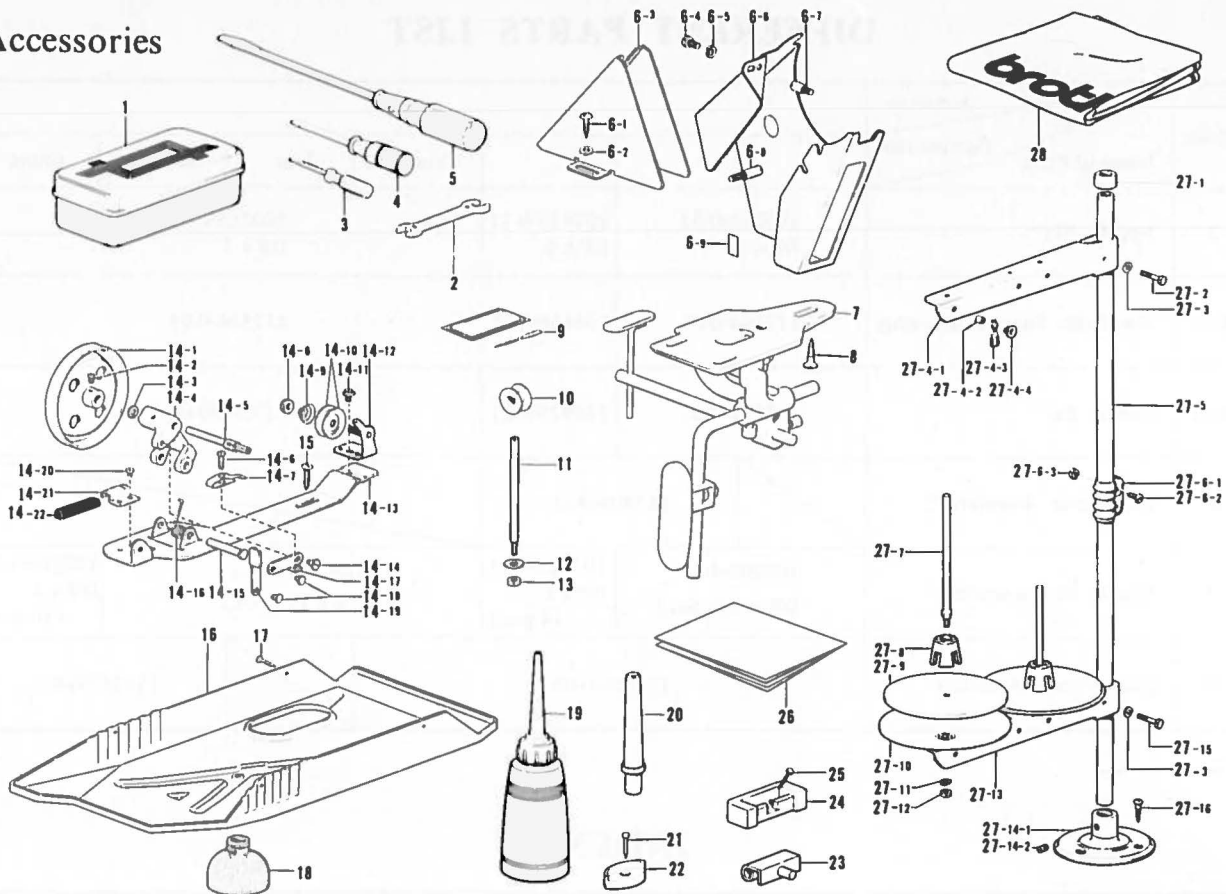

Ref. No.	Name of Parts	Q'ty	Parts No.	Assembly No.	Ref. No.	Name of Parts	Q'ty	Parts No.	Assembly No.
Z- 1	Accessory Box Assembly		110436-0-01		Z-14-21	Bobbin Winder Wheel Stopper Holder			Z-14
Z- 2	Spanner 8 x 9		100887-0-01		Z-14-22	Bobbin Winder Wheel Stopper		100662-0-01	117963-0-01
Z- 3	Screw Driver 1.9 x 52		142443-0-01		Z-15	Screw 5.5 x 20		100666-0-02	
Z- 4	Screw Driver 3.3 x 70		118837-0-01		Z-16	Oil Pan		117657-0-01	
Z- 5	Screw Driver 5.5 x 190		101572-1-01		Z-17	Nail		109714-0-00	
Z- 6- 1	Screw 5.5 x 20		100666-0-02	Z-6 Belt Cover Assembly C	Z-18	Oiler		117660-0-01	
Z- 6- 2	Washer 5.56		025750-1-32		Z-19	Oiler		114483-0-01	
Z- 6- 3	Belt Cover D				Z-20	Head Rest		100477-0-01	
Z- 6- 4	Screw 4.37 x 8		009680-8-12		Z-21	Nail		109714-0-00	
Z- 6- 5	Spring Washer 2-4.37		028680-2-42		Z-22	Head Cushion		148890-0-01	
Z- 6- 6	Belt Cover UC				Z-23	Hinge		143882-0-01	
Z- 6- 7	Stud C		147857-0-01		Z-24	Rubber Hinge		143910-0-01	
Z- 6- 8	Stud A		147855-0-01		Z-25	Nail		109714-0-00	
Z- 6- 9	Cushion 7 x 12		146289-0-01		Z-26	Table Sheet		149994-0-01	
Z- 7	Knee Lifter Assembly		113380-0-01		Z-27- 1	Cap			
Z- 8	Screw 6.2 x 32		106030-0-01	Z-27- 2	Bolt 5 x 28		017502-8-03		
Z- 9	Needle #11 Assembly			Z-27- 3	Washer 5		025050-2-33		
Z-10	Bobbin		146290-0-01	Z-27- 4-1	Spool Holder 2			Z-27-4 Thread Hanger Assembly	
Z-11	Spool Pin		118499-0-01	Z-27- 4-2	Thread Bushing		142990-0-01	150192-0-03	
Z-12	Washer		116662-0-01	Z-27- 4-3	Thread Guide Spring		150184-0-01		
Z-13	Nut 4.37		021680-2-02	Z-27- 4-4	Thread Hanger				
Z-14- 1	Bobbin Winder Wheel Assembly			Z-27- 5	Pipe		150172-0-00		
Z-14- 2	Screw 4.37 x 5		100366-0-02	Z-27- 6-1	Joint			Z-27-6 Joint for Cotton Stand	
Z-14- 3	Washer			Z-27- 6-2	Screw 5 x 14		150202-0-01	150106-0-01	
Z-14- 4	Bobbin Winder Wheel Shaft Supporter			Z-27- 6-3	Nut 5		021500-1-03		
Z-14- 5	Bobbin Winder Shaft		117970-0-01	Z-27- 7	Spool Shaft B		150179-0-01		
Z-14- 6	Screw 3.18		100657-0-01	Z-27- 8	Spool Cushion		147060-0-01		
Z-14- 7	Bobbin Presser		100656-0-01	Z-27- 9	Spool Mat		150182-0-00	Z-27 Cotton Stand Assembly	
Z-14- 8	Tension Control Nut			Z-27-10	Spool Stand Base		150180-0-00		
Z-14- 9	Tension Spring		100401-0-01	Z-27-11	Spring Washer 2-5		028050-2-43		
Z-14-10	Tension Disc		145446-0-01	Z-27-12	Nut 5		021500-1-03		
Z-14-11	Screw 4.37			Z-27-13	Spool Holder 2		150178-0-01		
Z-14-12	Bobbin Winder Guide Assembly			Z-27-14-1	Cotton Stand Base		150189-0-01	Z-27-14 Cotton Stand Base Assembly	
Z-14-13	Bobbin Winder Wheel Bracket			Z-27-14-2	Screw 6 x 7		150181-0-01		
Z-14-14	Screw 3.18		100659-0-01	Z-27-15	Bolt 5 x 28		017502-8-03		
Z-14-15	Pin			Z-27-16	Screw 4.5 x 22		013452-2-03		
Z-14-16	Spring		117969-0-01	Z-28	Head Cover		144222-0-01		
Z-14-17	Bobbin Presser Arm								
Z-14-18	Pin								
Z-14-19	Bobbin Presser Bracket								
Z-14-20	Screw 3.57 x 3.5		009679-3-12						

*The details of included accessories are subject to change.

*Les détails des accessoires inclus sont sujets à des changements.

*Änderungen in der Aufstellung der mitgelieferten Zubehöre sind vorbehalten. *Los detalles de los accesorios incluidos pueden variar.

DIFFERENT PARTS LIST

Ref.No.	Sub-class Name of Parts	-1					
		Destination		Taiwan	Iran	Mexico	China
B- 2	Needle #11	100265-0-31 DB x 1	107415-0-11 DP x 5	100265-0-31 DB x 1			
B-10	Needle Bar Support Assembly	117544-0-01	154438-0-01	117544-0-01			
B-10-1	Needle Bar	117546-0-01	153928-0-01	117546-0-01			
Z- 6	Belt Cover Assembly C	147905-0-11					
Z- 9	Needle #11 Assembly	100265-4-31 DB x 1 (4 pcs.)	107415-4-11 DP x 5 (4 pcs.)	100265-4-31 DB x 1 (4 pcs.)		100265-1-31 DB x 1 (10 pcs.)	
Z-27	Cotton Stand Assembly	150150-0-03					150150-0-03

INDEX

Parts No.	Ref. No.	Remark	Parts No.	Ref. No.	Remark	Parts No.	Ref. No.	Remark	Parts No.	Ref. No.	Remark
001670-6-12	C- 4		100251-0-01	C- 5- 2		103796-0-01	C- 6		116735-0-00	B-14- 5	
	E-17			C-13- 2		103950-0-02	A-26		116966-0-00	E- 4	
009660-3-12	D-32			D- 8- 2		104449-0-01	A-11		116967-0-00	E- 7	
009670-4-12	A- 4		100257-0-10	A-15		104478-0-01	B-32		116968-0-00	F-14	
009670-6-13	C-34			A-17		104689-0-01	D-14			E-28	
	C-43			D-39		104908-0-01	D-22		116969-0-00	E-12	
009671-4-12	E-20			D-41			D-48		116981-0-00	A-19	
009679-3-12	Z-14-20			E- 8			D-55- 4		116984-0-00	E-27	
009680-8-12	Z- 6- 4		100265-0-31	B- 2		105163-0-01	B- 9		117006-0-01	E- 5	
009681-6-12	D-45		100265-1-31	Z- 9		105299-0-03	C-22- 2			E-11	
009680-8-12	C- 2		100265-4-31	Z- 9			D-28		117007-0-01	E- 3	
009781-8-12	C-16- 2		100366-0-02	Z-14- 2		106030-0-01	Z- 8		117022-0-01	E-29	
009783-0-12	C- 1- 2		100386-0-01	A-14		106588-0-01	D-19		117533-1-01	A- 2	
013711-0-10	B- 8		100401-0-01	Z-14- 9		106629-0-01	D-21		117534-0-01	A-16	
	B-11		100402-0-04	A-27- 1		107407-0-03	B-16		117535-0-01	B-26	
	C-15		100477-0-01	Z-20			C-51		117542-0-00	B-24	
013760-6-10	B-27		100507-0-00	D-30		107415-0-11	B- 2		117543-0-00	B-19	
	C- 8		100511-0-01	D-44		107415-4-11	Z- 9		117544-0-01	B-10	
	D-11		100633-0-01	C-25		108808-0-01	E-16		117546-0-01	B-10- 1	
013761-4-10	B-21			C-29		108960-0-04	A- 8		117547-0-01	B- 6	
	B-31			C-39		109405-0-01	E-24		117549-0-01	B- 5	
	C-12			D- 5		109714-0-00	Z-17		117550-0-01	B-14	
013780-8-10	B-25		100656-0-01	Z-14- 7			Z-21		117553-0-01	B-14- 1	
017502-8-03	Z-27- 2		100657-0-01	Z-14- 6			Z-25		117560-0-01	B-15- 1	
	Z-27-15		100659-0-01	Z-14-14		109993-0-01	E- 1		117563-0-01	D-47	
021500-1-03	Z-27- 6- 3		100662-0-01	Z-14-22		110124-0-01	B-15- 3		117565-0-01	D-49	
	Z-27-12		100666-0-02	Z- 6- 1		110367-0-01	B-17		117566-0-01	D-46	
021680-2-02	Z-13			Z-15		110436-0-01	Z- 1		117567-0-01	D-53	
025050-2-33	Z-27- 3		100887-0-01	Z- 2		111191-0-01	E- 6		117568-0-01	D-54	
025750-1-32	Z- 6- 2		101572-1-01	Z- 5		111937-0-01	A-13		117569-0-01	C-10	
028050-2-43	Z-27-11		101706-0-01	C-33- 2		112999-0-00	E-26		117570-0-01	C- 7	
028060-2-42	Z- 6- 5			C-45- 2		112636-0-01	D-55- 1		117571-0-01	C-11	
031452-2-03	Z-27-16			D- 2		113031-0-01	B- 4		117577-0-01	C-28	
047501-2-42	D-55- 3			D- 6- 2		113380-0-01	Z- 7		117580-0-01	C-17	
048060-3-42	D-51			D- 7- 2		114483-0-01	Z-19		117581-0-01	C-18	
100080-0-03	B-15- 5		101706-0-03	C- 9- 2		114909-0-00	D-52		117582-0-01	C-26	
100248-0-01	B-23			C-24- 2		114931-0-02	A-24		117583-0-01	C-30	
	B-29		102731-0-02	A- 6					117584-0-01	C-20	
100250-0-01	B-20		102843-0-02	C-38		116629-0-01	D-50			C-32	
100251-0-01	B-18		103790-0-01	C- 5- 4		116662-0-01	Z-12		117587-0-01	C-35	

Parts No.	Ref. No.	Remark	Parts No.	Ref. No.	Remark	Parts No.	Ref. No.	Remark	Parts No.	Ref. No.	Remark
117588-0-01	C-36		118837-0-01	Z- 4		181938-0-01	C-46- 3				
117589-0-01	C-42		122771-0-02	B- 1- 3		182392-0-01	C-46- 2				
117590-0-01	C-41		123006-0-01	D-27							
117591-0-01	C-37		140521-0-01	D-33		107474-0-02	A- 1				
	E-13		140536-0-01	C-14		145446-0-01	Z-14-10				
117592-0-01	C-44		140553-0-01	B- 3		151601-0-02	D-55- 4				
117594-0-01	C-49		140740-0-01	C-16		151609-0-01	D-55				
117595-0-01	C-50		142443-0-01	Z- 3							
117596-0-01	C-46		142990-0-01	Z-27- 4- 2							
117597-0-01	D-13		143882-0-01	Z-23							
117598-0-01	D-12		143910-0-01	Z-24							
117599-0-00	D-10		144105-0-00	A-27- 7							
117600-0-01	D- 9		144222-0-01	Z-28							
117603-0-00	D- 3		145250-0-01	A-27- 2							
117608-0-01	D-17- 2		145446-0-01	A-27- 5							
117609-0-01	D-25		145465-0-01	B-14- 3							
117610-0-01	D-23			C-44- 2							
117611-0-00	D-26		145486-0-01	D-16							
117612-0-01	D-42		146289-0-01	Z- 6- 9							
117613-0-01	D-31		146290-0-01	C-47							
117614-0-01	D-18			Z-10							
117615-0-01	D-20		147060-0-01	Z-27- 8							
117616-0-01	D-40		147646-0-01	B-15- 2							
117617-0-01	D-35		147647-0-01	D-17							
117618-0-01	D-34		147648-0-01	D-17- 1							
117619-0-01	D-37		147649-0-01	D-15							
117620-0-00	D-36		147732-0-01	B-15- 6							
117632-0-01	A-27- 4		147855-0-01	Z- 6- 8							
117633-0-01	A-27- 6		147857-0-01	Z- 6- 7							
117636-0-01	A- 5		148302-0-01	E-23							
117637-0-01	A- 7		147905-0-11	Z- 6							
117640-0-01	A- 9		148309-0-01	B- 1							
117642-0-01	E-15		148310-0-01	B- 1- 2							
117643-0-01	E- 9		148890-1-01	Z-22							
117644-0-00	E-10		148919-0-01	A-18							
117656-0-00	E- 2		149994-0-01	Z-26							
117657-0-01	Z-16		150106-0-01	Z-26- 6							
117660-0-01	Z-18		150139-0-01	Z-26-14							
117677-0-01	C-48		150150-0-03	Z-27							
117934-0-01	A-12		150172-0-01	Z-27- 5							
117935-0-01	A- 3		150178-0-01	Z-27-13							
117936-0-01	A-10		150179-0-01	Z-27- 7							
117937-0-01	B-22		150180-0-00	Z-27-10							
117938-0-01	B-28		150181-0-01	Z-27-14- 2							
117939-0-01	B-12		150182-0-00	Z-27- 9							
117941-0-01	B-30		150184-0-01	Z-27- 4- 3							
117945-0-01	C- 3		150189-0-01	Z-27-14- 1							
117946-0-00	C-23		150192-0-03	Z-27- 4							
117947-0-01	D- 1		150202-0-01	Z-27- 6- 2							
117948-0-00	D-38		151012-0-01	A-27- 8							
117953-0-01	E-21		151601-0-02	A-25							
117957-0-01	E-19		151603-0-02	D-29							
117958-0-01	E-18		151604-0-01	C-21							
117963-0-01	Z-14		151604-0-02	D-43							
117969-0-01	Z-14-16		151605-0-01	B-13							
117970-0-01	Z-14- 5			C-19							
118197-0-01	A-27- 3			C-27							
118278-0-01	C- 5			C-31							
118279-0-01	C-13			C-40							
118280-1-01	C- 1			D- 4							
118285-0-01	C-33			D-24							
118286-0-01	C-45		152973-0-01	E-22							
118299-0-01	C- 9			E-25							
	C-24		153928-0-01	B-10- 1							
118311-0-01	B- 7		154438-0-01	B-10							
118371-0-01	D- 8		158025-0-01	A-27							
118499-0-01	Z-11		180973-0-01	C-22							
118791-0-01	B-15- 4		180974-0-01	D- 7							
118793-0-01	B-14- 4		180975-0-01	D- 6							
118807-1-01	B-15		181937-0-01	C-46- 4							



118-861
195861-4-02
October, 1981
Printed in Japan

From the library of: Superior Sewing Machine & Supply LLC